

LHB SERIES LINEAR BAY LIGHT

Client:
 Project:
 Type:
 Quantity:

CONSTRUCTION

Full body steel housing constructed for shipment and job site durability.
 Channel includes top and side knockouts for simple and accessible wiring.

OPTICS

>95% efficiency optical grade polycarbonate clear lens for wide distribution.
 Optional frosted diffuser for glare reduction.

ELECTRICAL

80+ CRI LED.
 -40°C up to 55°C (-40°F up to 131°F) maximum operating temperature.
 60,000 hr LEDs at L70 @ 40°C.
 50/60Hz, <20% THD, >.9 Power Factor. 50,000 hr rated electronic driver.
 Driver operates at 120-277V input, 0-10V dimmable driver, down to 10%.
 Optional 347/480V input.
 Optional dimming sensor for occupancy and ambient light level detection.
 Optional external emergency battery for 120-277V / 480V application.

SENSOR (OPTIONAL)

SENSOR-819-O1 End mount on/off motion sensor lowbay lens (120-277)
 SENSOR-819-O2 End mount on/off motion sensor highbay lens (120-277V)
 SENSOR-819-D1 End mount programmable motion and photocell sensor lowbay lens (120-277V, 1-10V Dimming)
 SENSOR-819-D2 End mount programmable motion and photocell sensor highbay lens (120-277V, 1-10V Dimming)
 SENSOR-820 Integral programmable motion and photocell sensor highbay lens (347/480V, 0-10V Dimming)
 SENSOR-LSXR-10-ADC End mount programmable daylight harvesting sensor lowbay lens (120-277V, 0-10V Dimming)
 SENSOR-LSXR-6-ADC End mount programmable daylight harvesting sensor highbay lens (120-277V, 0-10V Dimming)
 SENSOR-LSXR-10-ADC-HVLT End mount programmable daylight harvesting sensor lowbay lens (480V, 0-10V Dimming)
 SENSOR-LSXR-6-ADC-HVLT End mount programmable daylight harvesting sensor highbay lens (480V, 0-10V Dimming)

MOUNTING

Adjustable aircraft cable hanger as standard mounting.

FINISH

All metal parts are post painted after fabrication with polyester powder coat paint with 90% reflectance.

CERTIFICATION

All luminaires are built to UL1598 standards and bear appropriate cULus labels.
 For Emergency application, equipment with UL924 certified battery packs.
 DLC® (DesignLights Consortium Qualified)

WARRANTY

5 year warranty, see Limited Warranty for additional information.



175 / 210W



90 / 130W

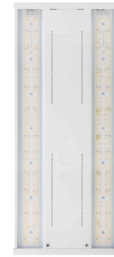

175 / 210W



270 / 300W

Shipping Data

Product	Measurement	Weight
LHB-90 / 130	17"L x 10"W x 2"H	6 lb
LHB-175 / 210	24"L x 10"W x 2"H	7 lb
LHB-270 / 300	36"L x 10"W x 2"H	10 lb



LHB SERIES LINEAR BAY LIGHT

Order Information **Example : LHB 130 50 FL WH UD**

Fixture	Series	Power & LM	CCT	Distribution	Finish	Input
	LHB			FL	WH	

**Accessories
Options**

A Series

LHB Linear Bay Light

B Power & LM

Code	Power	LM	LPW	Code	Power	LM	LPW
90	90W	12700lm	141	210	210W	30600lm	146
130	130W	18600lm	140	270	270W	37000lm	137
175	175W	25000lm	143	300	300W	41500lm	138

C CCT

40	4000K	50	5000K
----	-------	----	-------

D Distribution

FL Frosted Lens

E Finish

WH White

F Input

UD	120-277V, 0-10V Dimmable	HD	347-480V, 0-10V Dimmable
----	--------------------------	----	--------------------------

G Accessories/Options

blank	Adjustable aircraft cable hanging kit (standard)
WIREGUARD-LHB-A	Wireguard for LHB-90/130
WIREGUARD-LHB-B	Wireguard for LHB-170/210, LHBA-210 models
WIREGUARD-LHB-C	Wireguard for LHB-270/300
BAA	Assembled in America, compliant with BAA (COTS)
EMB-H15260*	90-Minute Self-Diagnostic Emergency Battery 15W 100-277VAC Input 170VDC Output for LHB 90/130/175/210
EMB-H40170*	90-Minute Self-Diagnostic Emergency Battery 40W 100-347VAC Input 170VDC Output
EMB-H40500*	90-Minute Self-Diagnostic Emergency Battery 40W 347-487VAC Input 500VDC Output
SENSOR-819-__*	End mount on/off motion sensor O1: Lowbay lens O2: Highbay Lens (120-277V)
SENSOR-819-__*	End mount programmable motion and photocell sensor D1: Lowbay lens D2: Highbay Lens (120-277V, 0-10V Dimming)
SENSOR-BLE-819-L1*	End Mount PIR Bluetooth Daylight Harvesting Sensor (ALS Control Mobile App) / L1: up to 20FT
CONTROL-LVFA*	AVI-ON Bluetooth Mesh Control System
REMOTE-RC100	Handheld Remote Commissioning Tool for SENSOR-819-D1/D2 Only, ANT Series
SURGE-LSP4-U / H	10kV surge protector (120-277V) 10kV surge protector (480V)
-CORD / CORD-H	18-3 300V cord (Specify length) / 18-3 600V cord (Specify length)
-PLUG	6ft standard length 18-3 300V cord with 3 prong plug
TWIST-LOCK	Specify Plug Type: L515P / L715P / HBL5929 / L8-20P

*see pg. 5 for spec

LHB SERIES LINEAR BAY LIGHT

Dimensions

Model	L	W	H
LHB-90 / 130	16.54" (420mm)	9.84" (250mm)	1.75" (44mm)
LHB-175 / 210	23.62" (600mm)	9.84" (250mm)	1.75" (44mm)
LHB-270 / 300	35.43" (900mm)	9.84" (250mm)	1.75" (44mm)

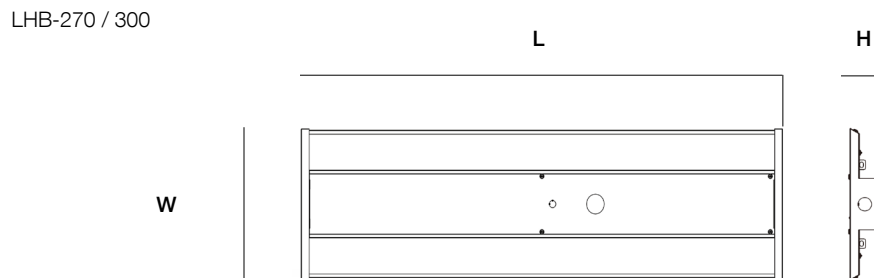
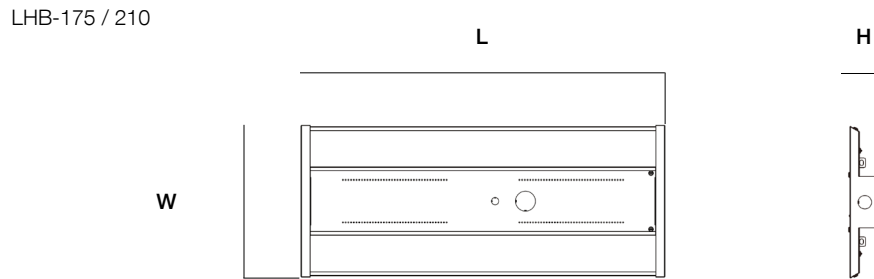
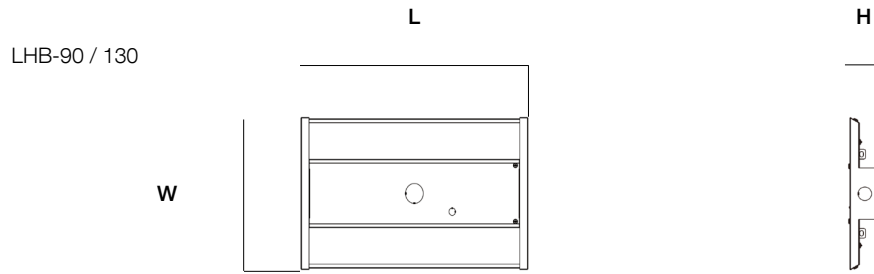

LHB SERIES LINEAR BAY LIGHT

PERFORMANCE DATA

SYSTEM WATTS	VOLTAGE	4000K / 5000K		QTY ON PALLET
		LUMENS	LPW	
90W	120-277V	12700	141	240
130W	120-277V	18600	143	240
175W	120-277V	25000	143	200
210W	120-277V	30600	146	200
270W	120-277V	37000	133	160
300W	120-277V	41500	135	160

DLC Code

Part Number	DLC Part Number	DLC Class
LHB - 90 40 FL WH UD / HD	S-8WOSQG	Standard
LHB - 90 50 FL WH UD / HD	S-7I4WCN	Standard
LHB - 130 40 FL WH UD / HD	S-GHN2DQ	Standard
LHB - 130 50 FL WH UD / HD	S-IJN8X3	Standard
LHB - 175 40 FL WH UD	S-ZSN6RC	Standard
LHB - 175 50 FL WH UD	S-KPQJEL	Standard
LHB - 210 40 FL WH UD / HD	S-LNAQFX	Standard
LHB - 210 50 FL WH UD / HD	S-FBW94K	Standard
LHB - 270 40 FL WH UD / HD	S-W8CFED	Standard
LHB - 270 50 FL WH UD / HD	S-65K1GB	Standard
LHB - 300 40 FL WH UD / HD	S-JZ017Y	Standard
LHB - 300 50 FL WH UD / HD	S-JRBPF6	Standard

LHB SERIES LINEAR BAY LIGHT

Sensor Spec

Model	Type	Mounting	Coverage	Input	Function	Programmable
SENSOR-819-O1 SENSOR-819-O2	PIR	20FT	30FT radius	Universal	On/Off	REMOTE-RC100
40FT		30FT radius				
SENSOR-819-D1 SENSOR-819-D2	PIR	20FT	30FT radius	Universal	On/Off/Dimming	REMOTE-RC100
40FT		30FT radius				
SENSOR-BLE-819 (see page 7 for detail)	PIR	L1 - 20FT	30FT radius	Universal	Bluetooth Mesh On/Off/Dimming Daylight Harvesting	ALS Control Bluetooth Mobile App
		L2 - 40FT	30FT radius			
CONTROL-LVFA (see page 6 for detail)	Fixture Controller	-	-	12V DC	Bluetooth Mesh On/Off/Dimming Scheduling	AVI-ON Bluetooth Mobile App



SENSOR-819-XX
 SENSOR-BLE-819



CONTROL-LVFA

EMB SPEC

Model	Battery Capacity	Input	Output	Output Power	Operating Temp	Installation
EMB-H15260	90mins	100-277VAC	90-260VDC	15W	0°C ~ 50°C 32°F ~ 122°F	Factory or Field Install
EMB-H40170	90mins	100-347VAC	170VDC	40W	0°C ~ 50°C 32°F ~ 122°F	Factory or Field Install
EMB-H40500	90mins	347-480VAC	310~500VDC	40W	0°C ~ 50°C 32°F ~ 122°F	Factory or Field Install

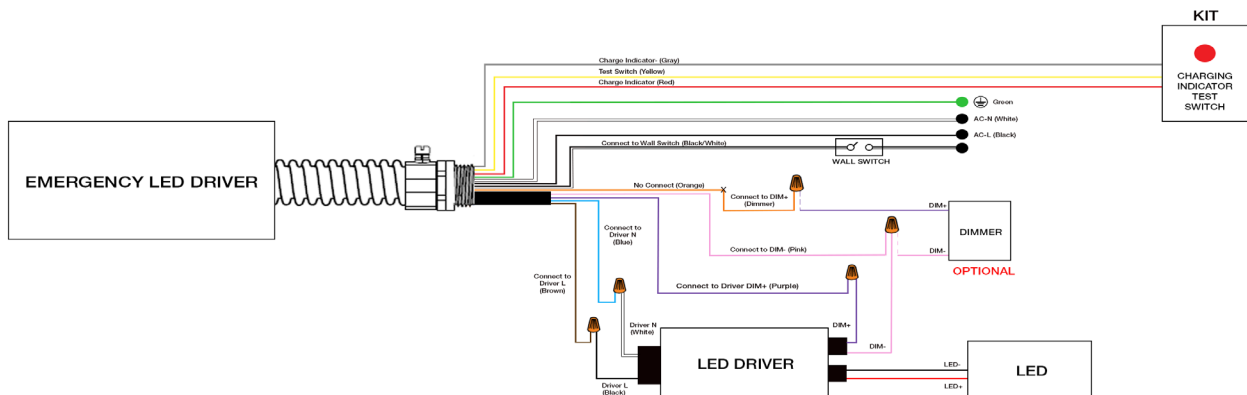

LHB SERIES LINEAR BAY LIGHT

CONTROL-LVFA SPEC

Status LEDs & Config Button

Quick and easy validation of wiring and network

Direct Connect™ Sensor Port

Simple and cost-effective addition to Avi-on sensors

Terminal Blocks & Mounting Tabs

Faster, easier and lower cost installation eliminating connectors

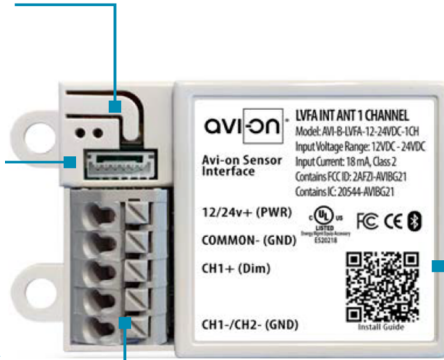

Internal Antenna

Improved performance and eliminates risk of accidentally cutting a hanging wire

SPECIFICATIONS

INPUT VOLTAGE: 12-24VDC
CURRENT: 15mA without a Sensor
 19mA with a DC PIR Sensor
 48mA with a DC Microwave Sensor
0-10V DIMMING: 12-24VDC
SIZE: 2.30in x 1.43in x 0.75in
 (58.2mm x 36.4mm x 19mm)
MOUNTING: Removable mounting tabs
WEIGHT: 0.45 oz (16g)
OPERATING TEMP: -22°F to +158°F (-30°C to + 70°C)

RADIO FREQUENCY: 2.4GHz
WIRELESS STANDARD: BLE 4.2 with Mesh
POINT TO POINT RANGE*: 80ft with obstructions
 350ft unobstructed
SECURITY: AES 128-bit encryption for device to device communication
 AES 256-bit encryption for device to cloud communication
WARRANTY: 5 years; 10 years optional
REGULATORY: FCC: 2AFZI-AVI1010 B
 IC: 20544-AVI1010 B
 BQB: D031801, DID: 86303
 UL 916, 2043 (Plenum Rated)

*When communicating through the mesh, range is essentially unlimited (5000ft+)

WIRING DIAGRAM

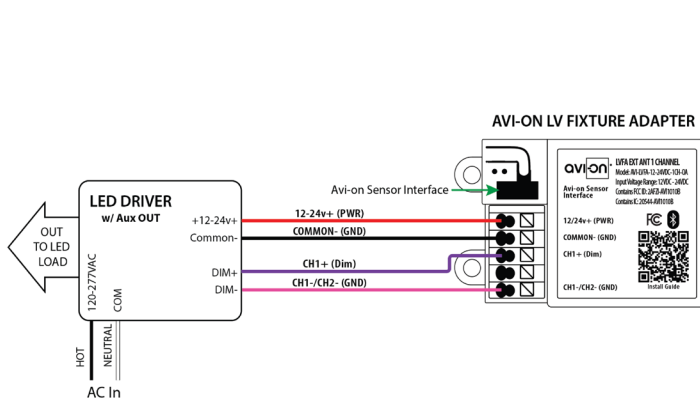

Fixture adapter powered by LED driver auxiliary output

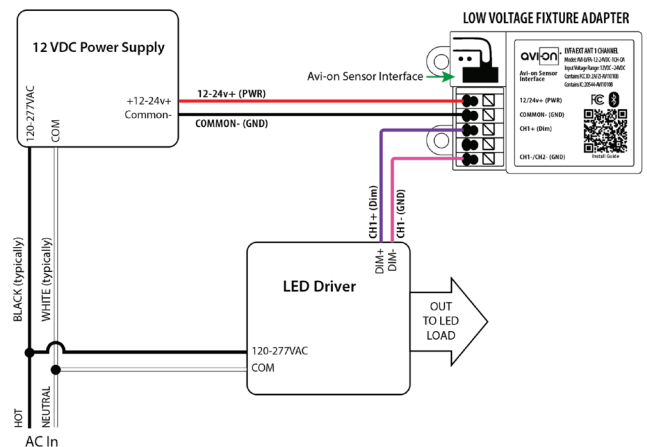

Fixture adapter connected to LED driver and using power supply

SENSOR-BLE-819 BLUETOOTH PIR SENSOR

FEATURE

- **Installation:** Factory or Field Install End Mount to Fixture
- **Commissioning:** Wirelessly through ALS Control Mobile App (iOS / Android)
- **Certification:** DLC 5.1 Networked Lighting Control System
- **Control:** Hold time, High-Low setting, continuous Bi-level dimming, Code-compliant manual-on or auto-off capability
- **Sensor:** Motion (Occupancy/Vacancy/Manual) and Daylight Harvesting
- **Room and Zone Control:** Zoning and Grouping control, Scheduling



SPECIFICATIONS

SENSOR TYPE: Passive Infrared Sensor (PIR)
WIRELESS STANDARDS: Bluetooth SIG Mesh
INPUT VOLTAGE: 120/277VAC
CONTROL OUTPUT: 0-10V
OPERATING TEMP: -40°F ~ +167°F (-40°C ~ +75°C)

COMMISSIONING RANGE: 50FT
BLUETOOTH RANGE: Integral antenna up to 100FT
DETECTION ANGLE: Vertical 90° x Horizontal 360°
MOUNTING HEIGHT: 8 - 40FT
WARRANTY: 5 years
IP RATING: IP20 Damp

DIMENSIONS

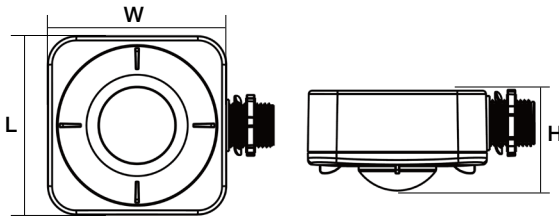

L	W	H
3.19" (81mm)	4.02" (102mm)	1.70" (43.3mm)

COVERAGE PATTERNS

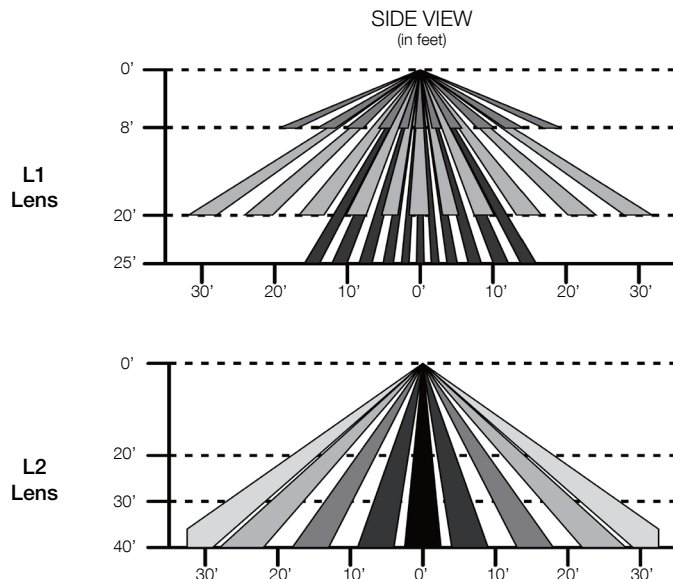

TOP VIEW
(in feet)

