



EX SERIES HAZARDOUS BAY LIGHT

Client:
Project:
Type:
Quantity:

CONSTRUCTION

Aluminum alloy (ADC12) die-cast housing, gasketed fixture, isolated electrical compartment, designed for Wastewater treatment, oil and gas refineries, drilling rigs, petrochemical facilities, food and beverage facilities, tunnels, outdoor general area lighting, and where flammable vapor, gas are present.

OPTICS

Clear shock & vibration resistant, 95% high transmittance tempered glass.

ELECTRICAL

>70CRI Bridgelux LED.
-40°C up to 55°C (-40°F up to 131°F) maximum operating temperature.
Long-life 54,000 hr LED at L70.
Driver operates at 120-277V input, 50/60Hz, <20% THD, 0.9 power factor.

MOUNTING

Trunnion Mount as standard.

STANDARD FINISH

Marine (salt water) grade (non-submerged) corrosion resistant matte Gray finish.

CERTIFICATION

IP68 Wet location label standard.
Luminaires are built to UL844, UL1598A, CSA C22.2 No. 137, CSA C22.2 No. 250.0; standards and bear appropriate cULus labels.
Class I, Div 2, Group A, B, C & D.
Gas environment Zone 1 & Zone 2.
Dust environment Zone 21 & Zone 22.
IEC/EN 60079-0, 7, 28, 31

WARRANTY

5 year warranty, see Limited Warranty for additional information.



SHIPPING DATA

Product	Measurement	Weight
EX-100	12”L x 12”W x 7”H	17 lb
EX-200	16”L x 16”W x 8”H	26 lb



EX SERIES HAZARDOUS BAY LIGHT

ORDER INFORMATION				EXAMPLE: EX 100 50 TR GR U		
Fixture	Series	Power & LM	CCT	Mounting	Finish	Input
	EX		50	TR	GR	U

A SERIES

EX Hazardous Bay Light

B POWER & LM

Code	Power	Lumen
100	100W	13,000lm
200	200W	16,000lm

C CCT

50 5000K

D MOUNTING

TR Trunion Mount

E FINISH

GR Gray Finish

F INPUT

U 120-277V

EX SERIES HAZARDOUS BAY LIGHT

DIMENSIONS

Model	L	W	H1	H2
EX-100	11.81" (300mm)	11.81" (300mm)	9.18" (233mm)	5.69" (145mm)
EX-200	15.75" (400mm)	15.75" (400mm)	8.94" (227mm)	5.91" (150mm)

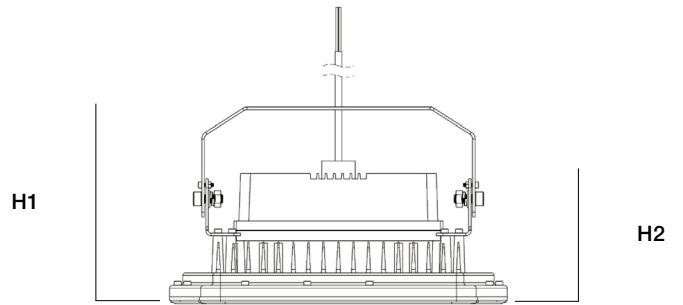
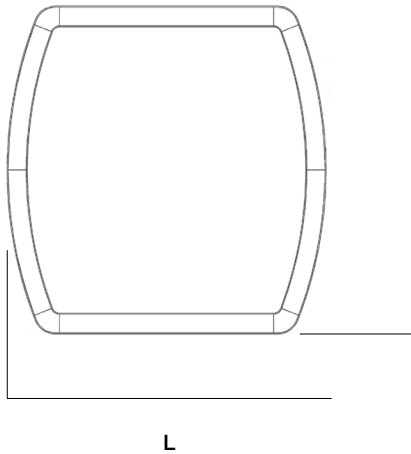

66° Swivel

